

Truss Connectors

TJC Jack Truss Connector

TJC is a versatile connector for jack trusses. Adjustable from 0 to 85 degree (shipped with 67.5 degree bend). Nail hole locations allow for easy installation.

- Minimum nailing option provides faster installation and lower installed cost.
- Can be used back-to-back on a single member (a load reduction applies, see table notes).

Material: 1.6mm thick.

Finish: Galvanised. See Corrosion Information.

Installation

- Use all specified fasteners. See General Notes.
- TJC37 can be installed filling round holes only, or filling round and triangle holes for maximum values.
- To reduce the potential for splitting, install the TJC with a minimum 5mm edge distance on the chord members.
- Position the jack truss on the inside of the bend line with the end of the jack truss flush with the bend line.
- Bend the TJC to the desired position (one bend cycle only).
- No bevel cut required.
- Attachment of TJC to the top chord requires the Designer to check connection geometry for placement on both carried and carrying chord members. See Top Chord Member Sizes table below for suggested chord sizes.
- Supported jack member is a minimum 39mm think.

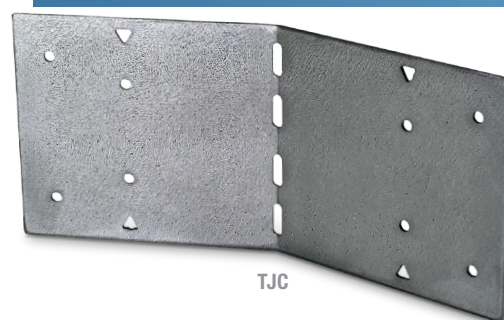
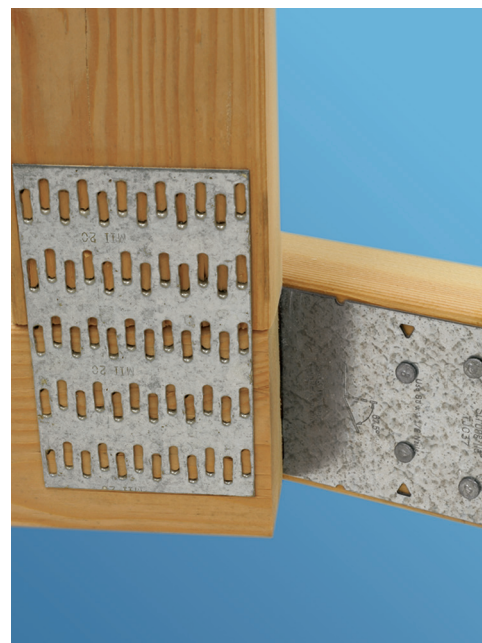

Truss Connectors

Typical Installation

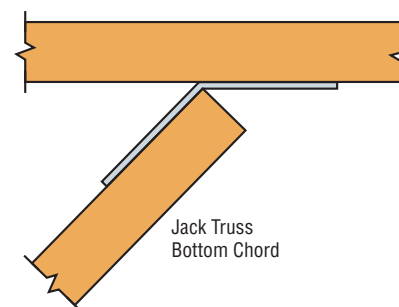
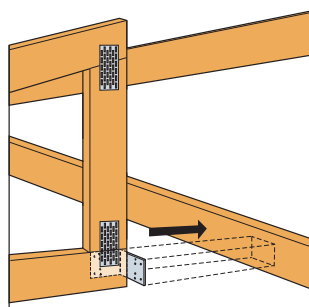
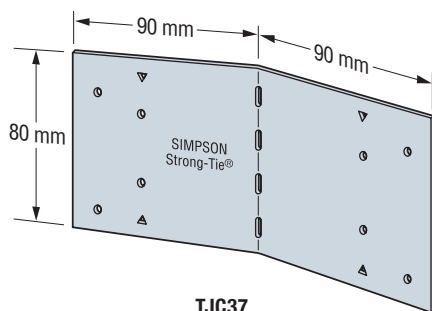

TJC Technical Data

Model No.	Fasteners (No. – Length x Dia., mm)		Country	Design Capacity (kN)								
	Carrying Member	Carried Member		0°		1° to 60°		61° to 67.5°		68° to 85°		
				Floor	Roof	Floor	Roof	Floor	Roof	Floor	Roof	
TJC37 (Min)	4 – 30 x 2.8	4 – 30 x 2.8	AU	$k_f = 0.69$	$k_f = 0.77$	$k_f = 0.69$	$k_f = 0.77$	$k_f = 0.69$	$k_f = 0.77$	$k_f = 0.69$	$k_f = 0.77$	
			NZ	1.21	1.21	1.20	1.20	1.40	1.40	1.14	1.14	
TJC37 (Max)	6 – 30 x 2.8	6 – 30 x 2.8	AU	$k_f = 0.69$	$k_f = 0.77$	$k_f = 0.69$	$k_f = 0.77$	$k_f = 0.69$	$k_f = 0.77$	$k_f = 0.69$	$k_f = 0.77$	
			NZ	2.69	2.69	2.03	2.03	1.75	1.75	2.04	2.04	
			AU	$k_f = 0.80$	$k_f = 0.80$	$k_f = 0.80$	$k_f = 0.80$	$k_f = 0.80$	$k_f = 0.80$	$k_f = 0.80$	$k_f = 0.80$	$k_f = 0.80$
			NZ	1.21	1.21	1.20	1.20	1.31	1.31	1.14	1.14	

1. Design Capacity is the lesser of (1) the Characteristic Capacity multiplied by the Australian Capacity Factor, or the NZ Strength Reduction Factor (ϕ), and applicable the k modification factors following AS 1720.1 and NZS 3603 and (2) the Serviceability Capacity which is the load at 3.2mm joint slip. Design Capacity is the minimum of test data and structural joint calculation.
2. For Australia, the Capacity Factor (ϕ) is 0.85 for nails and screws for structural joints in a Category 1 application. Reduce tabulated values where other Category applications govern. For NZ, the Strength Reduction Factor (ϕ) is 0.80 for nails in lateral load and 0.70 for other fasteners.
3. Duration of Load Factor (k_t) is as shown. Reduce Duration of Load Factor where applicable. Capacities may not be increased.
4. Timber species for joint design is seasoned Radiata Pine, which is Australia Joint Group JD4 per AS 1720.1 Table H2.4 and New Zealand Joint Group J5 per NZS 3603 Table 4.1.
5. TJC37 requires a single-ply carried member with minimum 89 x 38mm chord members.
6. For back-to-back installation on a single-ply girder/hip member, use a 0.70 reduction of table loads.
7. Design capacities are for an upward or downward direction.